

SECTION **CL**  
CLUTCH

A  
B  
C

CL

CONTENTS

E

<b>PRECAUTION</b> .....	2	Inspection and Adjustment .....	10	F
<b>PRECAUTIONS</b> .....	2	<b>CLUTCH MASTER CYLINDER</b> .....	12	G
Precaution for Supplemental Restraint System (SRS) "AIR BAG" and "SEAT BELT PRE-TENSIONER" .....	2	Exploded View .....	12	
General Precautions .....	2	Removal and Installation .....	12	
<b>PREPARATION</b> .....	3	Inspection and Adjustment .....	13	
<b>PREPARATION</b> .....	3	<b>CLUTCH PIPING</b> .....	14	H
Special Service Tools .....	3	Exploded View .....	14	
Commercial Service Tools .....	3	Hydraulic Layout .....	14	
<b>SYMPTOM DIAGNOSIS</b> .....	4	Removal and Installation .....	14	I
<b>NOISE, VIBRATION AND HARSHNESS (NVH) TROUBLESHOOTING</b> .....	4	Inspection and Adjustment .....	15	
NVH Troubleshooting Chart .....	4	<b>UNIT REMOVAL AND INSTALLATION</b> .....	16	J
<b>PERIODIC MAINTENANCE</b> .....	5	<b>CSC (CONCENTRIC SLAVE CYLINDER)</b> .....	16	K
<b>CLUTCH PEDAL</b> .....	5	Exploded View .....	16	
Inspection and Adjustment .....	5	Removal and Installation .....	16	
<b>CLUTCH FLUID</b> .....	6	Inspection and Adjustment .....	17	
Inspection .....	6	<b>CLUTCH DISC AND CLUTCH COVER</b> .....	18	L
Draining .....	6	Exploded View .....	18	
Refilling .....	7	Removal and Installation .....	18	
Air Bleeding .....	8	Inspection .....	19	M
<b>REMOVAL AND INSTALLATION</b> .....	10	<b>SERVICE DATA AND SPECIFICATIONS (SDS)</b> .....	21	N
<b>CLUTCH PEDAL</b> .....	10	<b>SERVICE DATA AND SPECIFICATIONS (SDS)</b> .....	21	O
Exploded View .....	10	General Specifications .....	21	
Removal and Installation .....	10	Clutch Pedal .....	21	
		Clutch Disc .....	21	
		Clutch Cover .....	21	P

# PRECAUTIONS

< PRECAUTION >

## PRECAUTION

### PRECAUTIONS

#### Precaution for Supplemental Restraint System (SRS) "AIR BAG" and "SEAT BELT PRE-TENSIONER"

INFOID:000000009267485

The Supplemental Restraint System such as "AIR BAG" and "SEAT BELT PRE-TENSIONER", used along with a front seat belt, helps to reduce the risk or severity of injury to the driver and front passenger for certain types of collision. This system includes seat belt switch inputs and dual stage front air bag modules. The SRS system uses the seat belt switches to determine the front air bag deployment, and may only deploy one front air bag, depending on the severity of a collision and whether the front occupants are belted or unbelted. Information necessary to service the system safely is included in the SR and SB section of this Service Manual.

#### **WARNING:**

- To avoid rendering the SRS inoperative, which could increase the risk of personal injury or death in the event of a collision which would result in air bag inflation, all maintenance must be performed by an authorized NISSAN/INFINITI dealer.
- Improper maintenance, including incorrect removal and installation of the SRS, can lead to personal injury caused by unintentional activation of the system. For removal of Spiral Cable and Air Bag Module, see the SR section.
- Do not use electrical test equipment on any circuit related to the SRS unless instructed to in this Service Manual. SRS wiring harnesses can be identified by yellow and/or orange harnesses or harness connectors.

#### PRECAUTIONS WHEN USING POWER TOOLS (AIR OR ELECTRIC) AND HAMMERS

#### **WARNING:**

- When working near the Airbag Diagnosis Sensor Unit or other Airbag System sensors with the Ignition ON or engine running, DO NOT use air or electric power tools or strike near the sensor(s) with a hammer. Heavy vibration could activate the sensor(s) and deploy the air bag(s), possibly causing serious injury.
- When using air or electric power tools or hammers, always switch the Ignition OFF, disconnect the battery, and wait at least 3 minutes before performing any service.

#### General Precautions

INFOID:000000009267486

#### **WARNING:**

After cleaning clutch disc, wipe it with a dust collector. Do not use compressed air.

#### **CAUTION:**

- Always use recommended clutch fluid. Refer to [MA-12, "Fluids and Lubricants"](#).
- Do not reuse drained clutch fluid.
- Keep painted surface on the body and other parts free of clutch fluid. If fluid spills, wipe up immediately and wash the affected area with water.
- Do not use mineral oils, such as gasoline or kerosene. It will ruin the rubber parts of the hydraulic system.
- Do not reuse CSC (Concentric Slave Cylinder). CSC slides back to the original position every time when removing transaxle assembly. At this time, dust on the sliding parts may damage the seal of CSC and may cause clutch fluid leakage. Refer to [CL-16, "Removal and Installation"](#).
- Do not disassemble clutch master cylinder and CSC.

# PREPARATION

< PREPARATION >

## PREPARATION

### PREPARATION

#### Special Service Tools



INFOID:000000009267487

The actual shapes of Kent-Moore tools may differ from those of special service tools illustrated here.

Tool number (Kent-Moore No.) Tool name	Description
ST20050240 ( — ) Diaphragm adjusting wrench  ZZA0508D	Adjusting unevenness of diaphragm spring lever

#### Commercial Service Tools

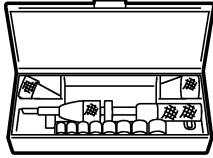
INFOID:000000009267488

Tool name	Description
Clutch aligner  MCIB0404E	Installing clutch disc
Power tool  PIIB1407E	Loosening nuts, screws and bolts

# NOISE, VIBRATION AND HARSHNESS (NVH) TROUBLESHOOTING

< SYMPTOM DIAGNOSIS >

## SYMPTOM DIAGNOSIS

### NOISE, VIBRATION AND HARSHNESS (NVH) TROUBLESHOOTING

#### NVH Troubleshooting Chart

INFOID:000000009267489

Use the chart below to find the cause of the symptom. The numbers indicate the order of the inspection. If necessary, repair or replace these parts.

Reference page	CL-5	CL-8	EM-82	CL-17	CL-19										EM-94	
SUSPECTED PARTS (Possible cause)	CLUTCH PEDAL (Inspection and adjustment)	CLUTCH LINE (Air in line)	ENGINE MOUNTING (Loose)	CSC (Concentric Slave Cylinder) (Worn, dirty or damaged)	CLUTCH DISC (Out of true)	CLUTCH DISC (Runout is excessive)	CLUTCH DISC (Lining broken)	CLUTCH DISC (Dirty or burned)	CLUTCH DISC (Oily)	CLUTCH DISC (Worn out)	CLUTCH DISC (Hardened)	CLUTCH DISC (Lack of spline grease)	DIAPHRAGM SPRING (Damaged)	DIAPHRAGM SPRING (Out of tip alignment)	PRESSURE PLATE (Distortion)	FLYWHEEL (Distortion)
Symptom	Clutch grabs/chatters		1			2			2	2	2			2		
	Clutch pedal spongy		1	2												
	Clutch noisy			1												
	Clutch slips	1							2	2			3		4	5
	Clutch does not disengage	1	2		3	3	3	3	3			3	4	4	5	

# CLUTCH PEDAL

< PERIODIC MAINTENANCE >

## PERIODIC MAINTENANCE

### CLUTCH PEDAL

#### Inspection and Adjustment

INFOID:000000009267490

1. Check to see if the master cylinder rod end moves freely. It should not be bound by the clutch pedal.
  - a. If the rod end does not move freely, remove the rod end and check for deformation or damage on the rod end. Leave the rod end removed for step 2.
2. Check the clutch pedal stroke for free range of movement.
  - a. With the master cylinder rod end removed, manually move the pedal up and down to determine if it moves freely.
  - b. If any sticking is noted, replace the clutch pedal assembly. Re-verify that the master cylinder rod end moves freely.
3. Adjust clutch interlock switch (1) position so that clearance between clutch pedal (2) and thread end of clutch interlock switch (1), with clutch pedal fully depressed, is within specification (C).

**Clearance (C) : 0.74 - 1.96 mm (0.0291 - 0.0772 in)**

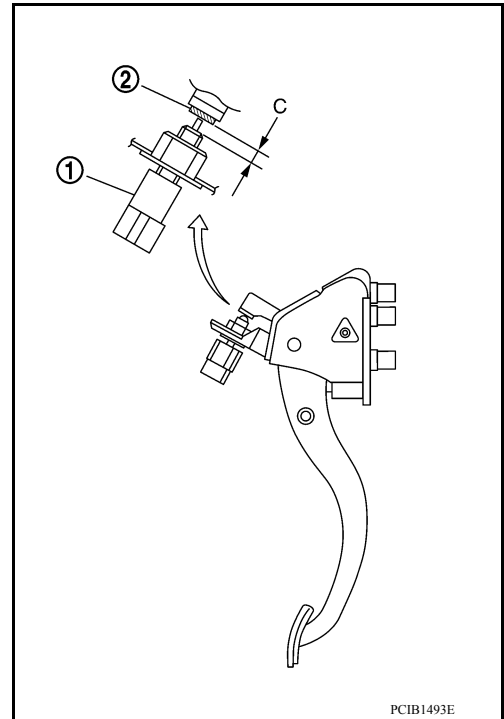
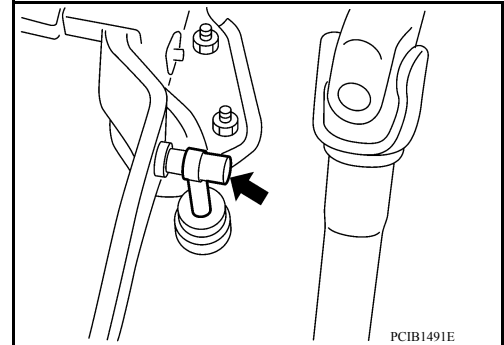

4. Check the clutch hydraulic system components (clutch master cylinder, clutch operating cylinder, clutch withdrawal lever and clutch release bearing) for sticking or binding.
  - a. If any sticking or binding is noted, repair or replace the related parts as necessary.
  - b. If any hydraulic system repair was necessary, bleed the clutch hydraulic system. Refer to [CL-8, "Air Bleeding"](#).

A  
B  
C  
CL  
E  
F  
G  
H  
I  
J  
K  
L  
M  
N  
O  
P

# CLUTCH FLUID

< PERIODIC MAINTENANCE >

## CLUTCH FLUID

### Inspection

INFOID:000000009267491

#### FLUID LEAKAGE

- Check clutch line for cracks, deterioration or other damage. Replace any damaged parts.
- Check for fluid leakage by fully depressing clutch pedal while engine is running.

**CAUTION:**

**If leaks occur around connections, reinstall the lines or replace damaged parts, if necessary.**

#### FLUID LEVEL

- Check that the fluid level in the reservoir tank is within the specified range, between the MAX and MIN lines as shown.
- Visually check for any clutch fluid leaks around the reservoir tank.
- Check the clutch system for any leaks if the fluid level is extremely low (lower than MIN).

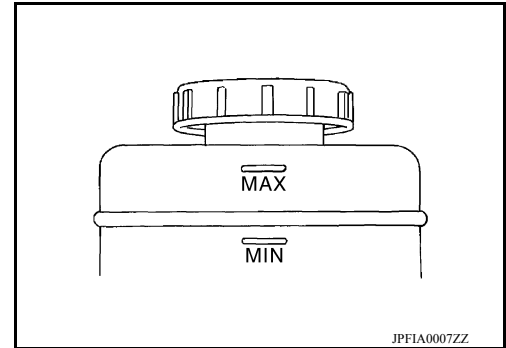

### Draining

INFOID:000000009267492

**CAUTION:**

**Do not spill clutch fluid onto painted surfaces. If fluid spills, wipe up immediately and wash the affected area with water.**

1. Connect a transparent vinyl hose to air bleeder of bleeding connector (1).

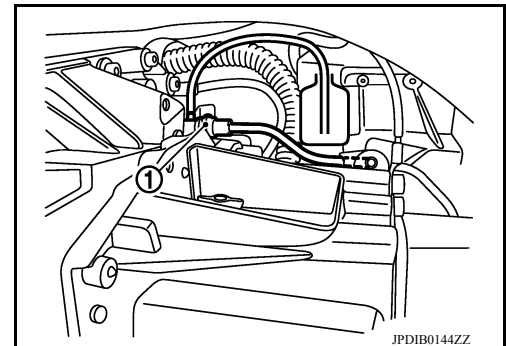

2. Press the lock pin (1) into the bleeding connector (2), and maintain the position.

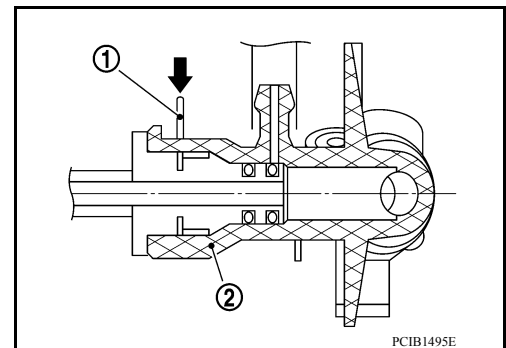

# CLUTCH FLUID

## < PERIODIC MAINTENANCE >

- Slide clutch tube (1) for the specified distance (A) in the direction of the arrow (←) as shown.

(2) : Bleeding connector

**Dimension (A) : 5 mm (0.20 in)**

**CAUTION:**

**Do not allow the clutch tube to disconnect from the bleeding connector.**

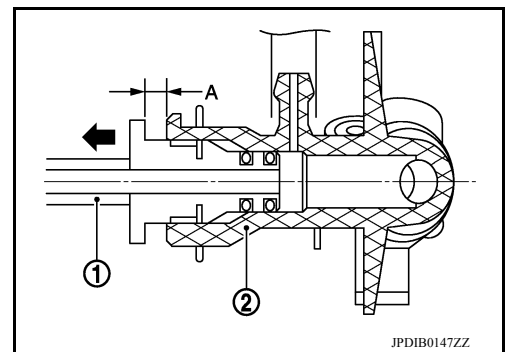

- Depress clutch pedal to gradually discharge clutch fluid.

**CAUTION:**

**Clutch tube is under hydraulic pressure; do not allow the clutch tube to disconnect from the bleeding connector.**

## Refilling

INFOID:000000009267493

**CAUTION:**

**Do not spill clutch fluid onto painted surfaces. If fluid spills, wipe up immediately and wash the affected area with water.**

- Check that there is no foreign material in reservoir tank and then fill with new clutch fluid.

**CAUTION:**

**Do not reuse drained clutch fluid.**

- Connect a transparent vinyl hose to air bleeder of bleeding connector (1).

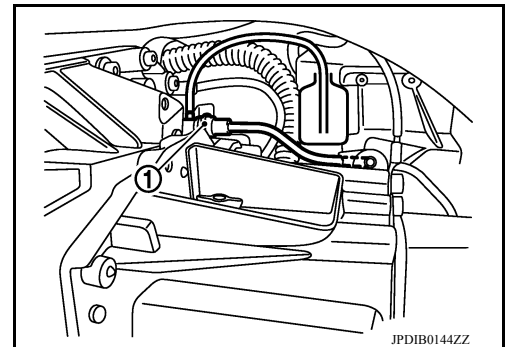

- Press the lock pin (1) into the bleeding connector (2), and maintain the position.

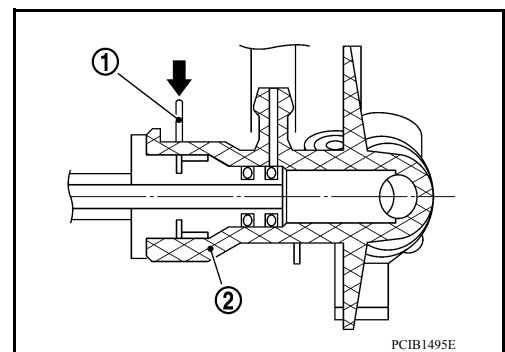

A  
B  
C  
CL  
E  
F  
G  
H  
I  
J  
K  
L  
M  
N  
O  
P

# CLUTCH FLUID

## < PERIODIC MAINTENANCE >

- Slide clutch tube (1) for the specified distance (A) in the direction of the arrow (←) as shown.

(2) : Bleeding connector

**Dimension (A) : 5 mm (0.20 in)**

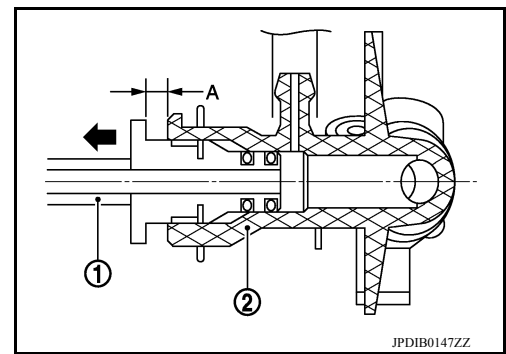

- Slowly depress clutch pedal to the full stroke position and then release the pedal.  
**CAUTION:**  
**Clutch tube is under hydraulic pressure; do not allow the clutch tube to disconnect from the bleeding connector.**
- Repeat step 5 at intervals of 2 or 3 seconds until new clutch fluid is discharged.  
**CAUTION:**  
**Monitor clutch fluid level in reservoir tank so as not to empty the tank.**
- Return clutch tube and lock pin in their original positions while clutch pedal is depressed.
- Perform the air bleeding. Refer to [CL-8. "Air Bleeding"](#).

## Air Bleeding

INFOID:000000009267494

### **CAUTION:**

- Monitor clutch fluid level in reservoir tank so as not to empty the tank.
- Do not spill clutch fluid onto painted surfaces. If fluid spills, wipe up immediately and wash the affected area with water.

- Fill reservoir tank with new clutch fluid.  
**CAUTION:**  
**Do not reuse drained clutch fluid.**
- Connect a transparent vinyl hose to air bleeder of bleeding connector (1).
- Depress and release the clutch pedal slowly and fully 15 times at an interval of 2 to 3 seconds and release the clutch pedal.

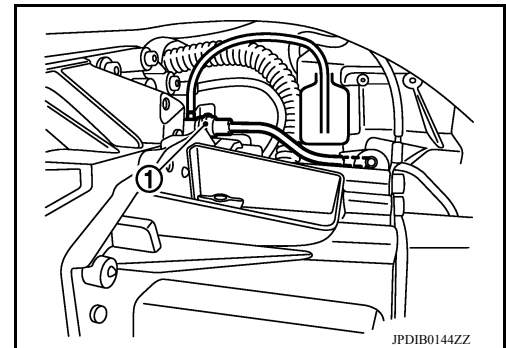

- Press the lock pin (1) into the bleeding connector (2), and maintain the position.

### **CAUTION:**

**Clutch tube is under hydraulic pressure; do not allow the clutch tube to disconnect from the bleeding connector.**

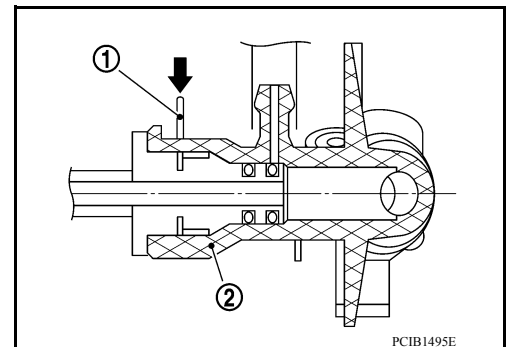



# CLUTCH FLUID

## < PERIODIC MAINTENANCE >

- Slide clutch tube (1) for the specified distance (A) in the direction of the arrow (←) as shown and immediately depress the clutch pedal and hold it, to bleed the air from the system.

(2) : Bleeding connector

**Dimension (A) : 5 mm (0.20 in)**

**CAUTION:**

**Clutch tube is under hydraulic pressure; do not allow the clutch tube to disconnect from the bleeding connector.**

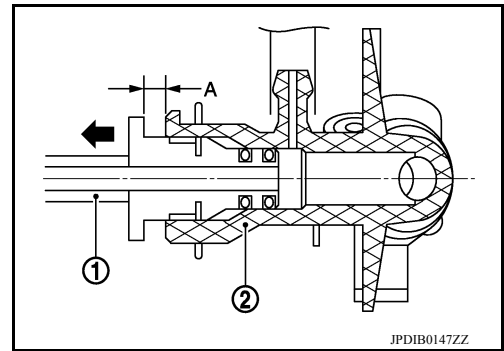

- Return clutch tube and lock pin in their original positions.
- Release clutch pedal and wait for 5 seconds.
- Repeat steps 3 to 7 until no bubbles are observed in the clutch fluid.
- Check that the fluid level in the reservoir tank is within the specified range after air bleeding. Refer to [CL-6, "Inspection"](#).

A  
B  
C  
CL  
E  
F  
G  
H  
I  
J  
K  
L  
M  
N  
O  
P

# CLUTCH PEDAL

< REMOVAL AND INSTALLATION >

## REMOVAL AND INSTALLATION

### CLUTCH PEDAL

Exploded View

INFOID:000000009267495

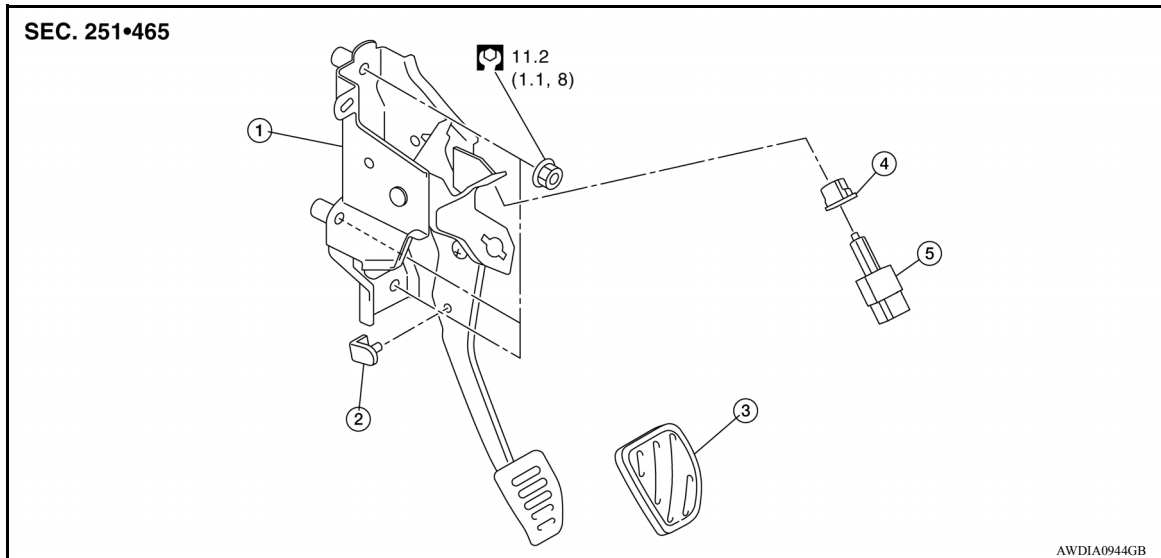

- |                 |                            |              |
|-----------------|----------------------------|--------------|
| 1. Clutch pedal | 2. Pedal stopper rubber    | 3. Pedal pad |
| 4. Clip         | 5. Clutch interlock switch |              |

### Removal and Installation

INFOID:000000009267496

#### REMOVAL

1. Remove the instrument lower panel LH. Refer to [IP-20, "Removal and Installation"](#).
2. Disconnect master cylinder rod end from clutch pedal.
3. Disconnect clutch interlock switch connector.
4. Remove harness clip from clutch pedal.
5. Remove clutch pedal nuts and remove clutch pedal from the vehicle.
6. Remove pedal pad from clutch pedal.
7. Remove clutch interlock switch and clip from clutch pedal.
8. Remove pedal stopper rubber from clutch pedal, using a suitable tool.

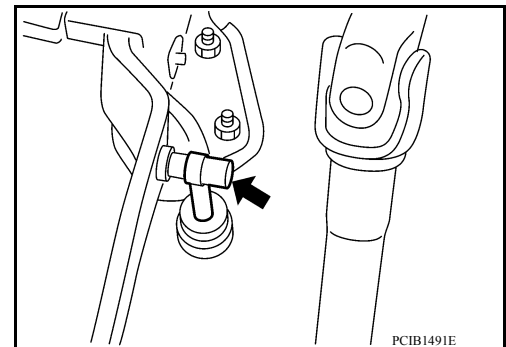

#### INSTALLATION

Installation is in the reverse order of removal.

#### **CAUTION:**

**Press master cylinder rod end into clutch pedal until it stops.**

#### Inspection and Adjustment

INFOID:000000009267497

#### INSPECTION AFTER REMOVAL

- Check clutch pedal for bend, damage, or a cracked weld. If bend, damage, or a cracked weld is found, replace clutch pedal.
- Check pedal stopper rubber. If damage or deformation is found, replace pedal stopper rubber.
- Check pedal pad. If wear or damage is found, replace pedal pad.

#### INSPECTION AND ADJUSTMENT AFTER INSTALLATION

# CLUTCH PEDAL

## < REMOVAL AND INSTALLATION >

Inspect the clutch interlock switch position and adjust as necessary. Refer to [CL-5. "Inspection and Adjustment"](#).

A

B

C

CL

E

F

G

H

I

J

K

L

M

N

O

P

# CLUTCH MASTER CYLINDER

< REMOVAL AND INSTALLATION >

## CLUTCH MASTER CYLINDER

Exploded View

INFOID:000000009267498

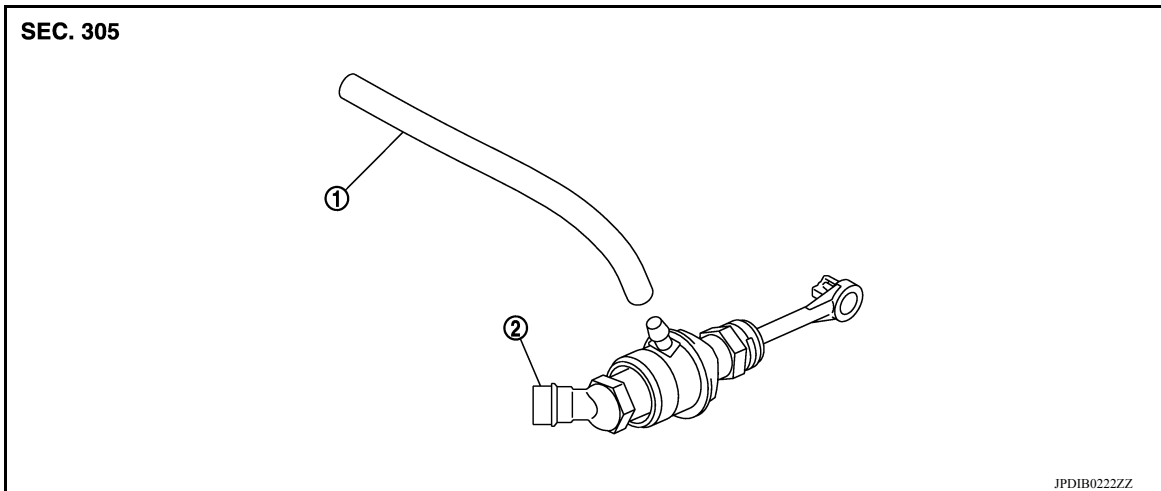

1. Reservoir hose
2. Master cylinder

## Removal and Installation

INFOID:000000009267499

### CAUTION:

- Do not spill clutch fluid onto painted surfaces. If fluid spills, wipe up immediately and wash the affected area with water.
- Do not disassemble clutch master cylinder.

### NOTE:

When removing components such as hoses, tubes/lines, etc., cap or plug openings to prevent fluid from spilling.

### REMOVAL

1. Remove battery. Refer to [PG-63. "Removal and Installation"](#).
2. Remove IPDM E/R bracket bolts (A) and nut (B).

⇐ : Front

3. Remove IPDM E/R bracket (1).

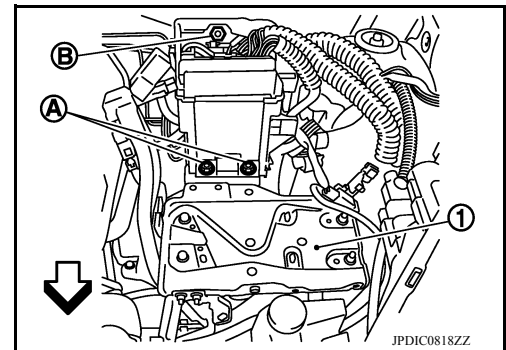

4. Remove ECM bracket nuts (A).

⇐ : Front

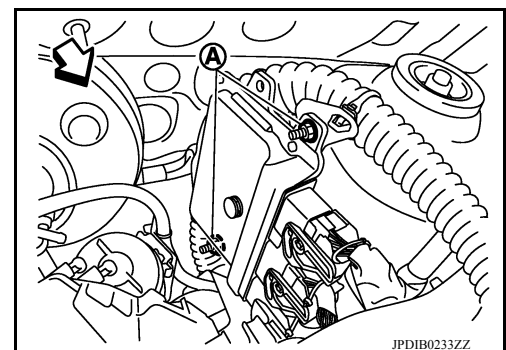

# CLUTCH MASTER CYLINDER

## < REMOVAL AND INSTALLATION >

5. Remove master cylinder rod end (←) from clutch pedal.
6. Use one of the following methods to remove hose from master cylinder.
  - Drain clutch fluid from reservoir tank and remove hose. Refer to [CL-6, "Draining"](#).
  - Remove hose from master cylinder.

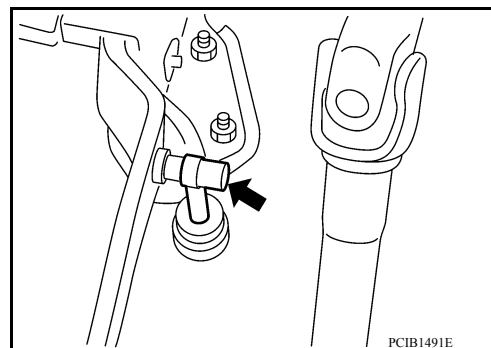

7. Pull up the lock pin (1) from connector of master cylinder (2) and separate clutch tube (3).
8. Rotate master cylinder clockwise by 45 degrees and then remove master cylinder from the vehicle.

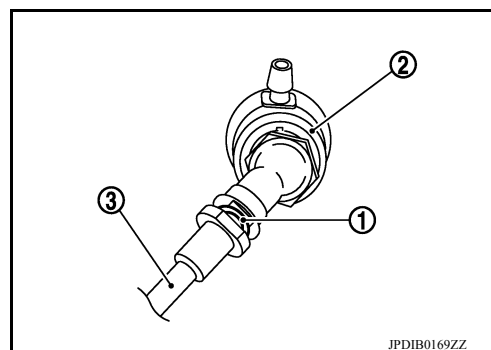

## INSTALLATION

### CAUTION:

**Do not spill clutch fluid onto painted surfaces. If fluid spills, wipe up immediately and wash the affected area with water.**

1. With the nipple (1) rotated clockwise by 45 degrees, insert clutch master cylinder into the mounting hole. Rotate the clutch master cylinder counterclockwise by 45 degrees (A) as shown to secure it. At this time, nipple is in the upward (B).
2. Install master cylinder rod end to clutch pedal.

### CAUTION:

**Press master cylinder rod end into clutch pedal until it stops.**

3. Install reservoir hose to master cylinder.
4. Press down the lock pin into connector of master cylinder until it stops.
5. Install clutch tube into connector of master cylinder until it stops.
6. Fill with clutch fluid and bleed clutch hydraulic system. Refer to [CL-7, "Refilling"](#).
7. Installation of the remaining components is in the reverse order of removal.

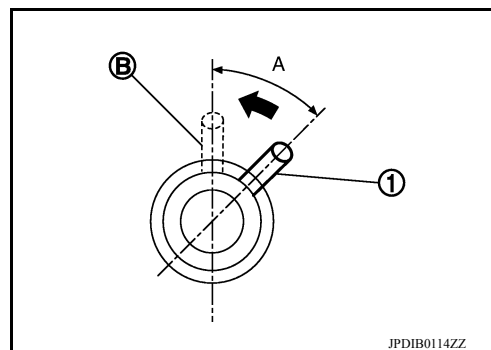

## Inspection and Adjustment

INFOID:00000009267500

## INSPECTION AFTER INSTALLATION

Check for fluid leakage and check the fluid level. Refer to [CL-6, "Inspection"](#).

# CLUTCH PIPING

< REMOVAL AND INSTALLATION >

## CLUTCH PIPING

Exploded View

INFOID:000000009267501

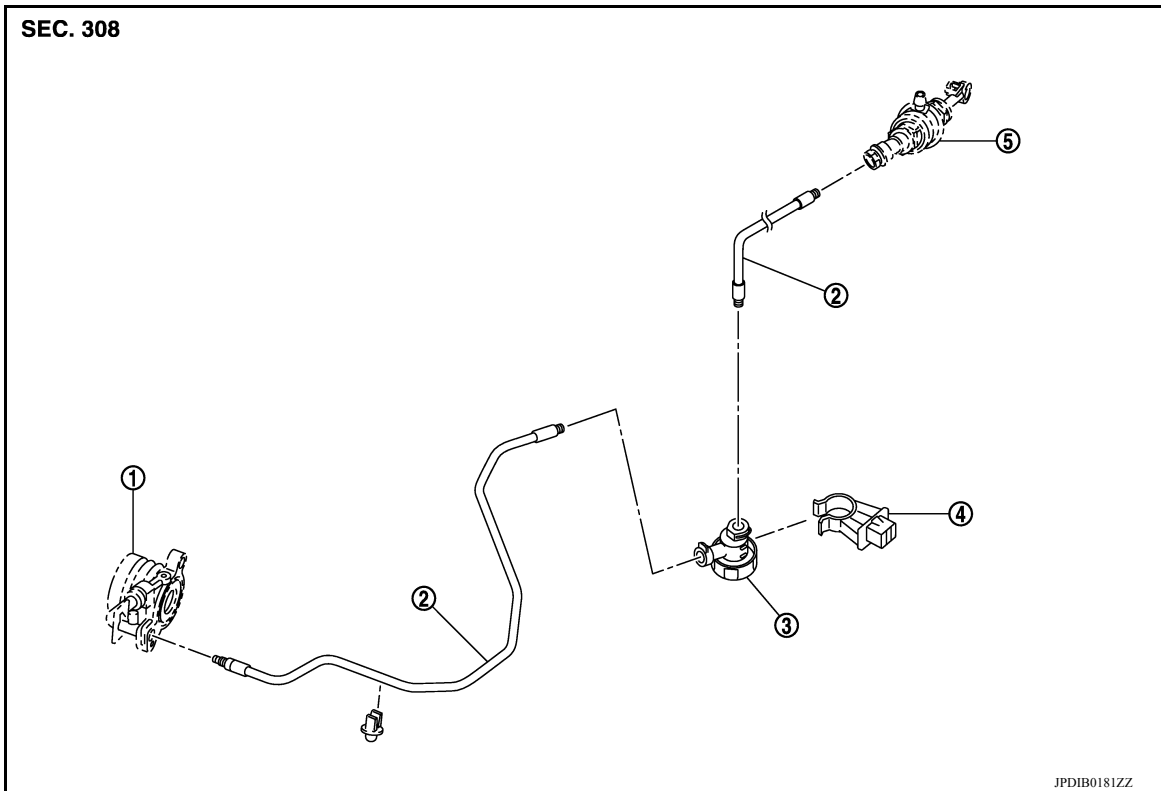

- 1. CSC (Concentric Slave Cylinder)
- 2. Clutch tube
- 3. Clutch damper
- 4. Bracket
- 5. Master cylinder

## Hydraulic Layout

INFOID:000000009267502

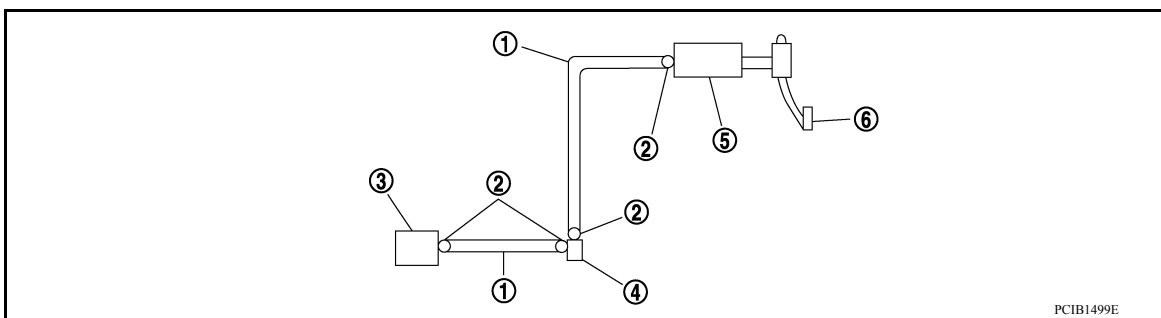

- 1. Clutch tube
- 2. Lock pin
- 3. CSC (concentric slave cylinder)
- 4. Clutch damper
- 5. Master cylinder
- 6. Clutch pedal

## Removal and Installation

INFOID:000000009267503

### CAUTION:

Do not spill clutch fluid onto painted surfaces. If fluid spills, wipe up immediately and wash the affected area with water.

### NOTE:

When removing components such as hoses, tubes/lines, etc., cap or plug openings to prevent fluid from spilling.

# CLUTCH PIPING

## < REMOVAL AND INSTALLATION >

### REMOVAL

1. Remove the battery. Refer to [PG-63. "Removal and Installation"](#).
2. Use one of the following methods to remove hose from clutch master cylinder.
  - Drain clutch fluid from reservoir tank and remove hose. Refer to [CL-6. "Draining"](#).
  - Remove hose from clutch master cylinder.
3. Remove clutch tube lock pin from clutch master cylinder.
4. Remove clutch tube lock pin at clutch housing.
5. Remove clutch tube lock pins (2) from clutch damper (3).
6. Remove clutch tube (1) from clutch damper (3).
7. Remove clutch damper (3) from bracket (4).

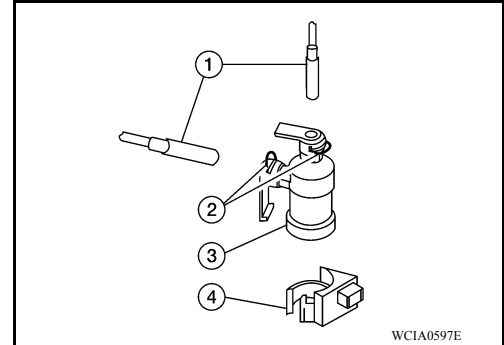

### INSTALLATION

Installation is in the reverse order of removal.

#### **CAUTION:**

#### **Do not damage clutch tube.**

- Insert each clutch tube into the CSC bleeding connector, the clutch damper connector, and the clutch master cylinder connector until it contacts the end of each connector.
- Install each lock pin into the clutch damper connector and the clutch master cylinder connector until it contacts the end of each connector.
- After installation, bleed the air from the clutch hydraulic system. Refer to [CL-8. "Air Bleeding"](#).

### Inspection and Adjustment

INFOID:000000009267504

#### INSPECTION AFTER REMOVAL

- Check the clutch tube for cracks and damage. If the clutch tube has cracks or damage, replace it with a new one.
- Check the O-ring of the clutch tube for cracks and damage. If the O-ring of the clutch tube has cracks or damage, replace clutch tube with a new one.
- Check the clutch damper for cracks and damage. If the clutch damper has cracks or damage, replace it with a new one.

#### INSPECTION AFTER INSTALLATION

Check for fluid leakage and check the fluid level. Refer to [CL-6. "Inspection"](#).

# CSC (CONCENTRIC SLAVE CYLINDER)

< UNIT REMOVAL AND INSTALLATION >

## UNIT REMOVAL AND INSTALLATION

### CSC (CONCENTRIC SLAVE CYLINDER)

Exploded View

INFOID:000000009267505

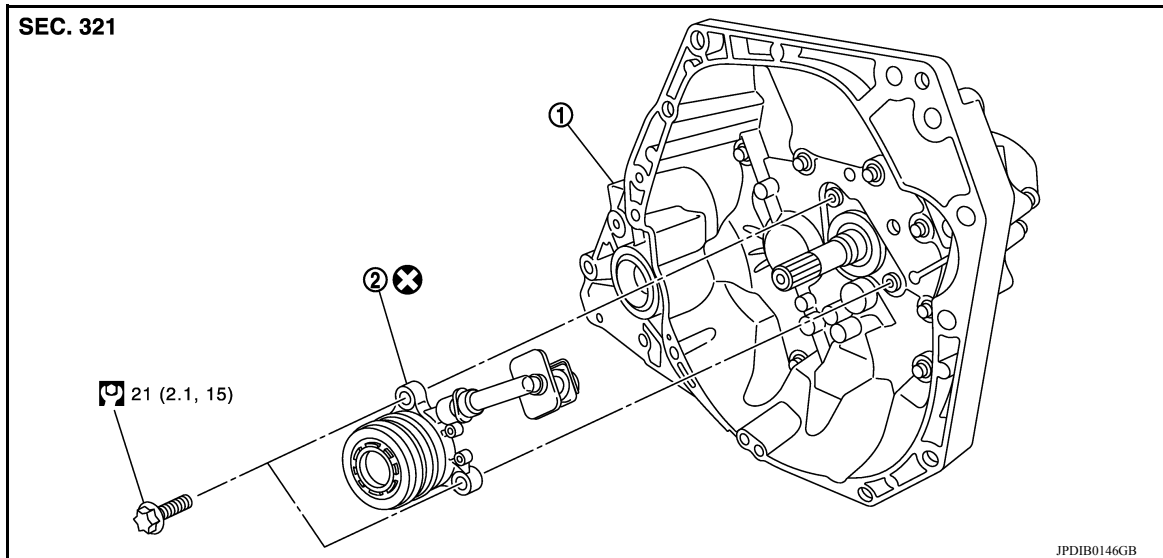

1. Transaxle assembly

2. CSC (concentric slave cylinder)

### Removal and Installation

INFOID:000000009267506

#### CAUTION:

- Do not reuse CSC (concentric slave cylinder). CSC slides back to the original position every time when removing transaxle assembly. At this time, dust on the sliding parts may damage the seal of CSC and may cause clutch fluid leakage.
- Do not disassemble CSC.
- Do not spill clutch fluid onto painted surfaces. If fluid spills, wipe up immediately and wash the affected area with water.

#### REMOVAL

1. Remove transaxle assembly. Refer to [TM-27, "Removal and Installation"](#).
2. Remove CSC bolts and the CSC from clutch housing.

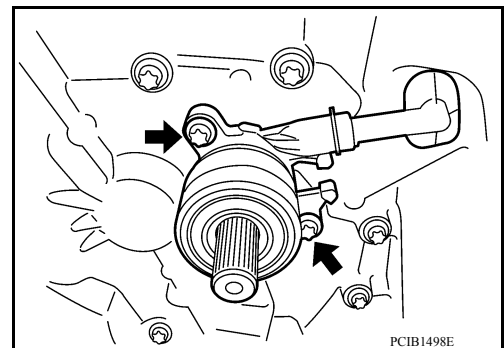

#### INSTALLATION

1. Install CSC to clutch housing and then tighten CSC bolts to the specified torque.

#### CAUTION:

- Do not reuse CSC.
  - Do not insert and operate CSC when transaxle is removed. Piston and stopper of CSC components may fall off.
2. Install transaxle assembly. Refer to [TM-27, "Removal and Installation"](#).



# CSC (CONCENTRIC SLAVE CYLINDER)

< UNIT REMOVAL AND INSTALLATION >

## Inspection and Adjustment

INFOID:000000009267507

### INSPECTION AFTER INSTALLATION

Check for fluid leakage and fluid level. Refer to [CL-6, "Inspection"](#).

### ADJUSTMENT AFTER INSTALLATION

Perform the air bleeding. Refer to [CL-8, "Air Bleeding"](#).

A

B

C

CL

E

F

G

H

I

J

K

L

M

N

O

P

# CLUTCH DISC AND CLUTCH COVER

< UNIT REMOVAL AND INSTALLATION >

## CLUTCH DISC AND CLUTCH COVER

Exploded View

INFOID:000000009267508

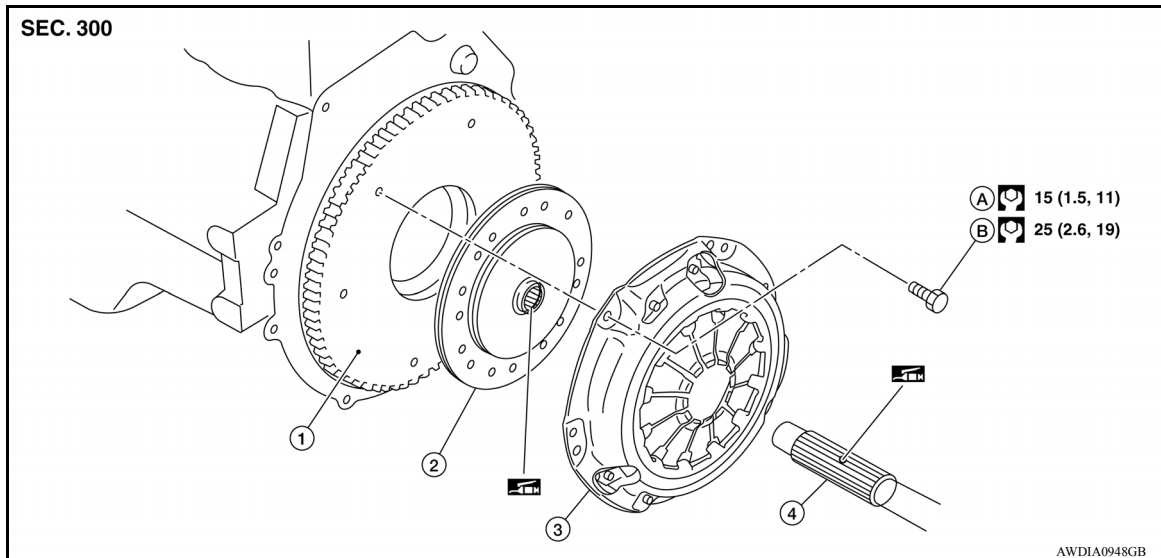

- |                |                |                 |
|----------------|----------------|-----------------|
| 1. Flywheel    | 2. Clutch disc | 3. Clutch cover |
| 4. Input shaft | A. First step  | B. Final step   |

: Apply lithium-based grease including molybdenum disulphide.

### Removal and Installation

INFOID:000000009267509

#### CAUTION:

- Do not reuse CSC (concentric slave cylinder). CSC slides back to the original position every time when removing transaxle assembly. At this time, dust on the sliding parts may damage the seal of CSC and may cause clutch fluid leakage.
- Do not allow any grease to contact the clutch disc facing, pressure plate surface and flywheel surface.
- Do not clean clutch disc using solvent.

#### REMOVAL

1. Remove transaxle assembly. Refer to [TM-27, "Removal and Installation"](#).
2. Loosen clutch cover bolts evenly. Then remove clutch cover and clutch disc.

#### INSTALLATION

1. Clean clutch disc and input shaft splines to remove grease and dust caused by abrasion.
2. Apply recommended grease to clutch disc and input shaft splines.

#### CAUTION:

Be sure to apply grease to the points specified. Otherwise, noise, poor disengagement, or damage to the clutch may result. Excessive grease may cause slip or shudder. If grease adheres to seal of CSC, it may cause clutch fluid leakage. Wipe off excess grease. Wipe off any grease oozing from the parts.

# CLUTCH DISC AND CLUTCH COVER

## < UNIT REMOVAL AND INSTALLATION >

3. Install clutch disc, using suitable tool (A).
4. Install clutch cover and then temporarily tighten clutch cover bolts.
5. Tighten clutch cover bolts to the specified torque evenly in two steps in the numerical order as shown.
6. Install transaxle assembly. Refer to [TM-27, "Removal and Installation"](#).

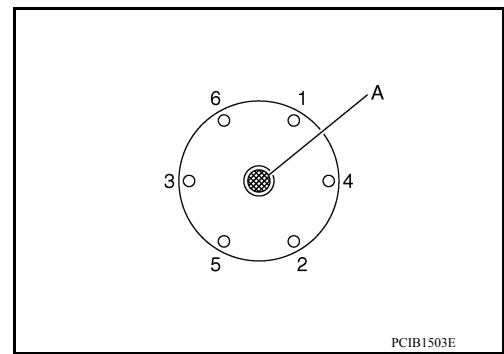

INFOID:000000009267510

## Inspection

### INSPECTION AFTER REMOVAL

#### Clutch Disc

- Measure clutch facing runout. If it is outside the specification, replace clutch disc.

**Runout limit/diameter of the area to be measured** : Refer to [CL-21, "Clutch Disc"](#).

- Measure spline backlash at outer edge of clutch disc. If it is outside the specification, replace clutch disc.

**Maximum allowable spline backlash (at outer edge of disc)** : Refer to [CL-21, "Clutch Disc"](#).

- Measure the depth (A) to clutch disc facing rivet heads, using suitable tool. If it exceeds the allowable wear limit, replace clutch disc.

**Facing wear limit (depth to the rivet head) (A)** : Refer to [CL-21, "Clutch Disc"](#).

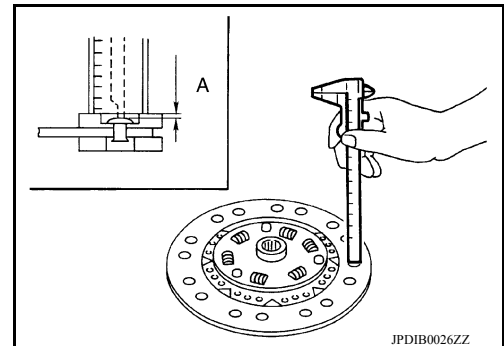
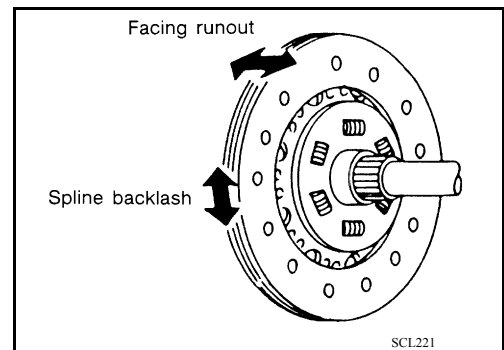

#### Clutch Cover

- Check clutch cover thrust ring for wear or damage. If wear or damage is found, replace clutch cover.

#### NOTE:

- Worn thrust ring will generate a beating noise when tapped at the rivet using suitable tool.
- Broken thrust ring will make a clinking sound when cover is shaken up and down.
- If a trace of burn or discoloration is found on the clutch cover pressure plate to clutch disc contact surface, repair the surface with sandpaper. If surface is damaged or distorted, replace clutch cover.

### INSPECTION AFTER INSTALLATION

#### Clutch Cover

## CLUTCH DISC AND CLUTCH COVER

### < UNIT REMOVAL AND INSTALLATION >

Check diaphragm spring levers for unevenness with the clutch cover installed on the engine. If they exceed the tolerance, adjust diaphragm spring lever height, using Tool (A).

**Tolerance for diaphragm spring lever unevenness** : Refer to [CL-21, "Clutch Cover"](#).

**Tool number** : ST20050240 ( — )

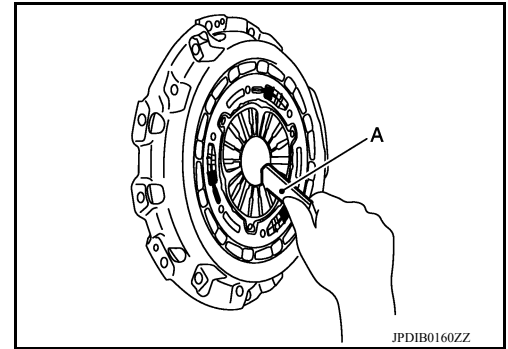

# SERVICE DATA AND SPECIFICATIONS (SDS)

< SERVICE DATA AND SPECIFICATIONS (SDS)

## SERVICE DATA AND SPECIFICATIONS (SDS)

### SERVICE DATA AND SPECIFICATIONS (SDS)

#### General Specifications

INFOID:000000009267511

Unit: mm (in)

Engine type	HR16DE
Type of clutch control	Hydraulic
Clutch disc Facing size (Outer dia. × Inner dia. × Thickness)	200 × 140 × 3.1 (7.87 × 5.51 × 0.122)
Recommended clutch fluid	Refer to <a href="#">MA-12. "Fluids and Lubricants"</a> .

#### Clutch Pedal

INFOID:000000009267512

Unit: mm (in)

Engine type	HR16DE
Clutch pedal height	158.8 – 168.8 (6.25 – 6.65)
Clutch pedal height at clutch disengagement	73 (2.87) or more
Clutch pedal play [Looseness at clutch pedal pin]	2 – 8 (0.08 – 0.31) [0 – 1.3 (0 – 0.051)]
Clearance between clutch pedal and clutch interlock switch threaded end while clutch pedal is fully depressed.	0.2 – 1.96 (0.008 – 0.0772)

#### Clutch Disc

INFOID:000000009267513

Unit: mm (in)

Engine type	HR16DE
Clutch facing runout limit / diameter of the area to be measured	1.0 (0.039) / 190 (7.48) dia.
Maximum allowable spline backlash (at outer edge of disc)	0.8 (0.031)
Clutch facing wear limit (depth to the rivet head)	0.3 (0.012)

#### Clutch Cover

INFOID:000000009267514

Unit: mm (in)

Engine type	HR16DE
Tolerance for diaphragm spring lever unevenness	0.7 (0.028) or less